

SIDE-POWER

Thruster systems



Product Specifications SP 40 S2i



Description

Typical boat size 25 - 32 foot (see back page for more info)
 Tunnel inside diameter 125 mm / 4,92"
 Propulsion system Single 4bl composite
 Available for DC system 12 V
 Weight 10 kg / 22 lbs.

Gearleg:

- Seawater resistant bronze, CNC machined in one process to ensure 100% correct tolerances, angles and measurements.
- Sealed gear leg with long-lif "mechanical" seal where polished ceramic and carbon surfaces form the only moving sealing surfaces, ensuring protection against damaging water intrusion into gear leg.
- Lifetime lubricated with special gear-oil.
- Hardened and ground precision spiro-conical gears.
- Propeller shaft with double ball bearings fitted in correct tolerances.
- Driveshaft with ball bearing and special sleeve bearing in correct tolerances.
- Connection between motor and driveshaft by shear-pin, changable from inside the boat.
- Symmetrical 4 bladed composite kaplan propeller.
- Zinc anode protection directly on gearleg, easy to access and change.

Thrusters are not only helpful for large yachts, typically a light weight boat with a single outboard or stern-drive are even more difficult and stressful to handle in tight spots than larger yachts that are less effected by the wind. In true SidePower spirit the SP 40 S2i includes all the important and unique Side-Power features and qualities - why settle for less.

Easy and safe to install:

- Easy access terminals for easy, fast and safe fitting of main battery cables (as opposed to having to fit directly onto "crowded" solenoid studs. Own by overheat sensor in motor.
- Plug and go control wiring.
- Fast, easy and safe fitting of propeller with lock-nut as opposed to difficult and unreliable set-screw fastening.
- Self aligning drilling template available for OEM customers.

Performance and specifications at one tunnel diameter depth * :

	at 10,5V	at 12,0V
Thrust	40 kg / 88 lbs.	47 kg / 99 lbs.
Output power	2,2 kW / 3 Hp	2,6 kW / 3,5 Hp
Average current draw	310 A	390 A
Continous run time (20°C)	3 min.	2 min 40 sec
Approx. long term run time	12% of time	10% of time
Min. battery CCA rating	300 by DIN / 525 by BCI/SAE	
Sidepower fuse size:	ANL250	

Safety features on thruster (see separate sheet for control panels):

- Forced shut-down by overheat sensor in motor
- All internal leads with extra insulation of webbed silicon increase resistance to heat and mechanical wear and connectors have positive lockign so that you have to pull by the insulation to release, can not be pulled off by the wires or loosen by themselves.
- IPC Standard electronic control box for protection against:
 - direct drive direction change
 - unique, patented protection of solenoid from extra wear and damages in low voltage situations for example caused by drained or damaged batteries as well as "auto-stop" without the need for the skipper to shut down the main switch immediatly to stop the thruster in case of a solenoid lock-in **
 - auto-stop if control signal is continous for more than 3 minutes to protect against potential short circuit in control cables.

Notes !

* Actual performances, current consumption etc. will vary for each installation depending on many factors. Specifications here given at one tunnel diameter depth and with voltage at thruster as shown. If you install deeper the thrust will be more as well as the current consumption, and the running time will be reduced. Electromotors power and efficiency tolerances are +/- 6%.

** New patented safety features in the thruster controlbox will be available in 2005 model year units.



SIDE-POWER

Thruster systems



Product Specifications SP 40 S2i

Installation planning:

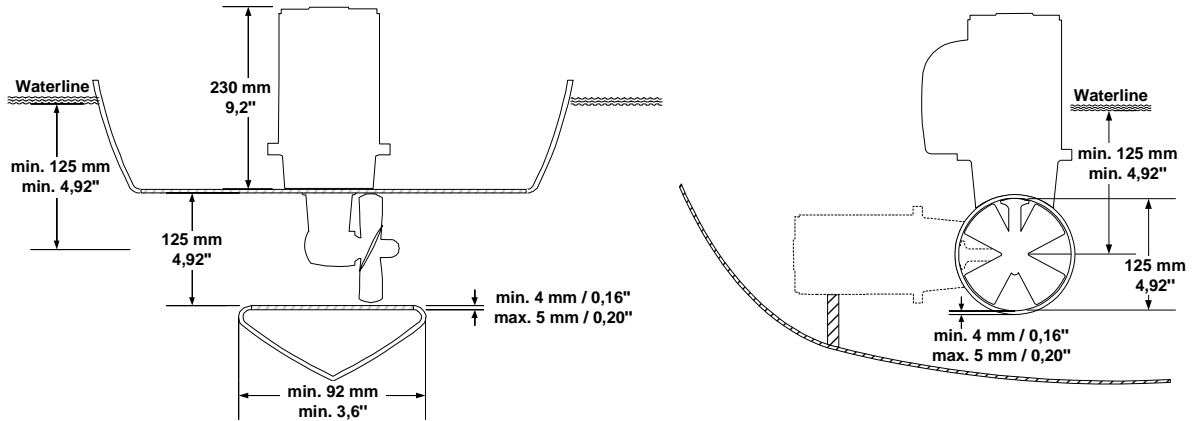

Table for selection of main cable, battery, fuse and main-switch sizes.			up to 7m total + & -		8 - 11m total + & -		12 - 15m total + & -		16 - 19m total + & -		20 - 23m total + & -	
Model	Voltage	Current draw	Min. Cable dimension	Min. Battery CCA by DIN	Min. Cable dimension	Min. Battery CCA by Din	Min. Cable dimension	Min. Battery CCA by DIN	Min. Cable dimension	Min. Battery CCA by Din	Min. Cable dimension	Min. Battery CCA by DIN
SP 40S2i	12 V	280 A	35 mm ² AWG 2	300 CCA Din	50 mm ² AWG 0	300 CCA Din	70 mm ² AWG 00	300 CCA Din	95 mm ² AWG 000	300 CCA Din	95 mm ² AWG 0000	300 CCA Din

Typical boat sizes:
SP40S2i push bow against a direct sidewind of approximately:

Bavaria 25 - 22,4 knots.



Benneteau Antares 760 - 22,2 knots.

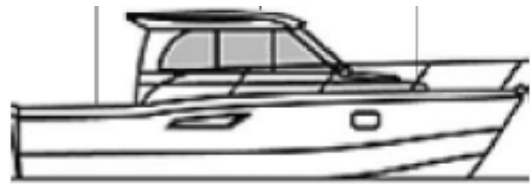

SeaRay 280 Sundancer - 22,1 knots.

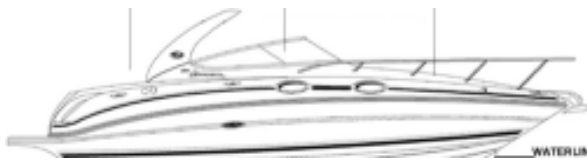

Fairline Targa 29 - 20,6 knots.



This document may contain typographical errors, to which Sleipner Motor assumes no responsibility.



Sleipner Motor AS
P.O. Box 519
N-1612 Fredrikstad
Norway

Tel: +47 69 30 00 60
Fax: +47 69 30 00 70

www.side-power.com
sidepower@sleipner.no

