

# SIDE-POWER

## Thruster systems



# SP 200 TC



### MAIN FEATURES

Thrust at 21 V	200 kg / 440 lbs.
Power	10 kW / 13,1 Hp
Tunnel diameter	250 mm / 9,8"
Propulsion system	Counter rotating
Voltage	24 V (12 V kit available)
Weight	68 kg / 150 lbs.
Boat size	50 - 80 foot
Current draw	nom. 670 A
Min. battery CCA DIN	650

This new thruster is specially built to give a maximum thrust in a minimum diameter.

A perfect choice for sailboats or as an upgrade thruster model for boats where the SP 155 TC is standard so that you can use the boat's "standard" tunnel size.

It will also be the most powerful choice for older boats with a 250 mm tunnel and a thruster which is too small from the time when these powerful DC thrusters were not available.

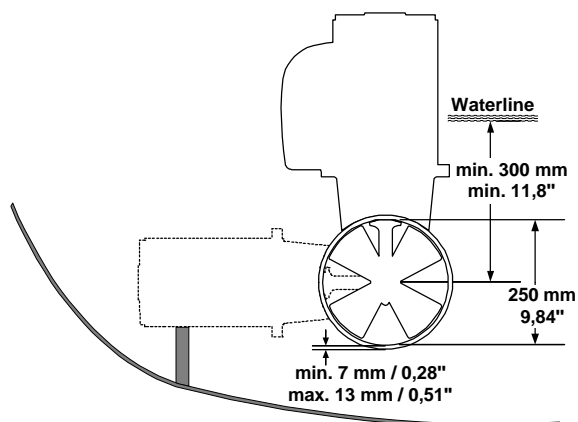
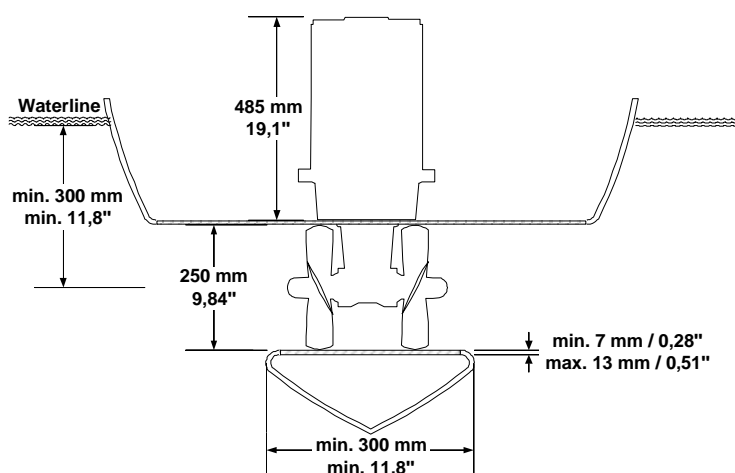

**Sleipner Motor AS**

P.O. Box 519  
N-1612 Fredrikstad  
Norway

Tel: +47 69 30 00 60  
Fax: +47 69 30 00 70

[www.side-power.com](http://www.side-power.com)  
[sidepower@sleipner.no](mailto:sidepower@sleipner.no)

