

Manufacturer: **Jakob Hatteland Display AS**  
 Product: **19.0 inch Military Display (MIL)**  
 Type: **JH 19T01 MIL**

Last Revised: **03 Mar 2006**  
 Revision#: **6**

## 19.0 inch Military Display (MIL)

### Features:

The color display described in this Data Sheet is an industrialized version of a high quality SHARP TFT based display with MVA Premium™ technology. The MIL allows you to display professional applications with clarity and enhanced color and image quality, BNC RGB input, BNC Video input and PiP (Picture in Picture) functions. The display provides you with automatic compatibility with multiple upgrading platforms and a vast array of graphics standards allowing resolution upgrades without upgrading the display.

The controller and the high light intensity in combination with the high contrast and wide backlight adjustment control, allow the product to be used in many environments. The brightness is adjustable from 0 to 100%

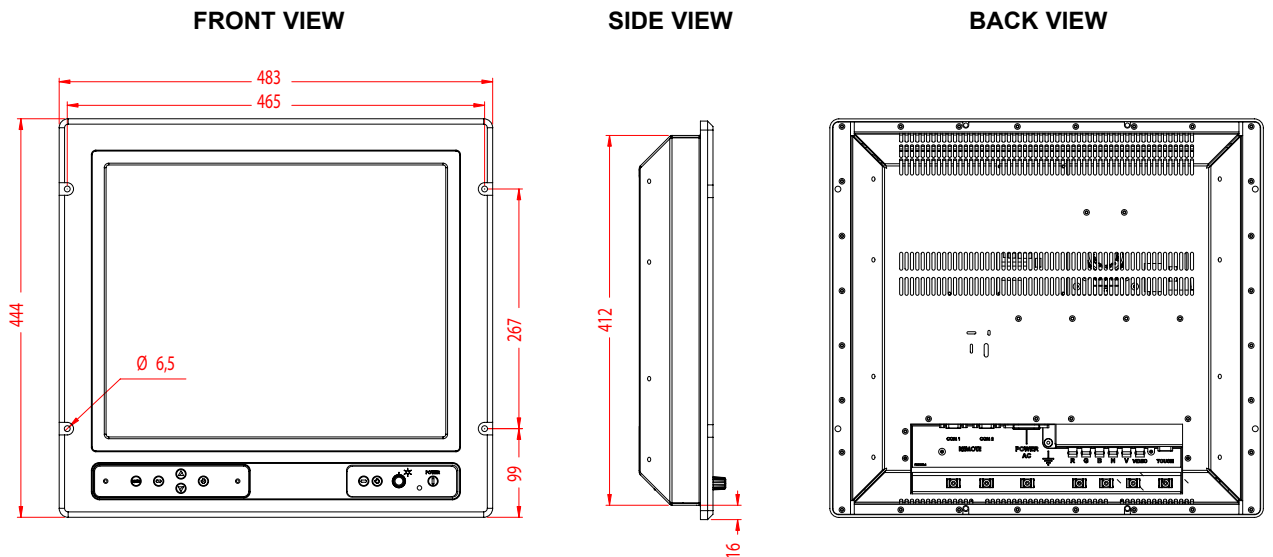

Due to dimensions without decimals, the tolerance on drawings is +/- 1mm (For accurate measurements, measure in AutoCAD)

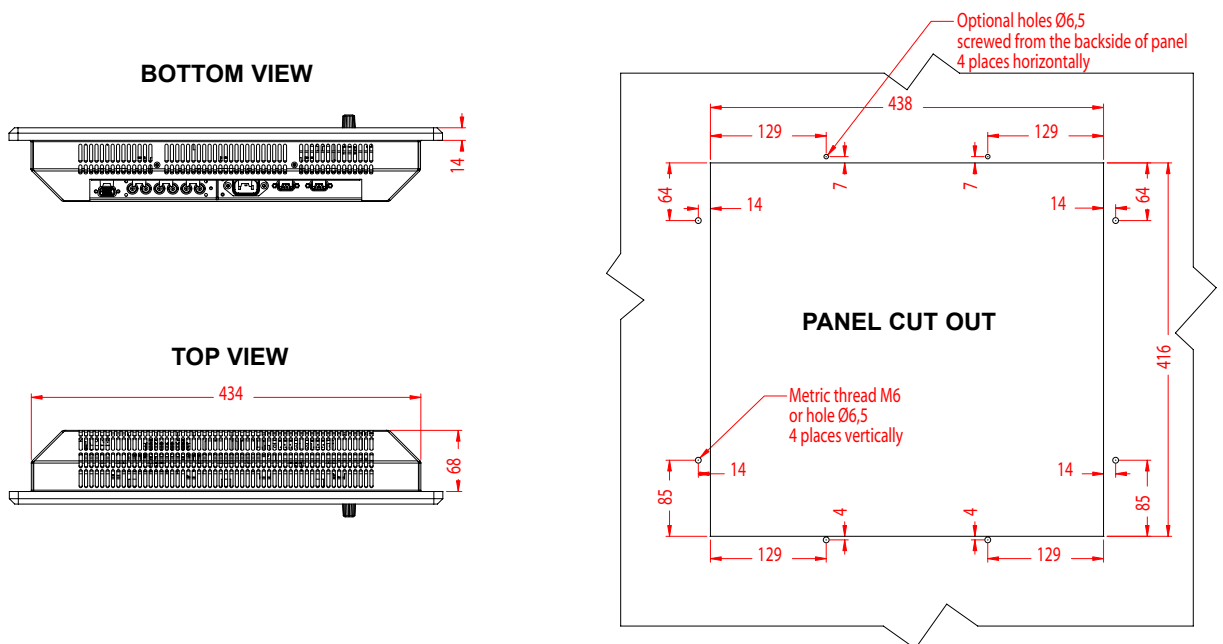

This information may not, in whole or in part, be copied, photocopied, reproduced, translated or reduced to any electronic medium or machine-readable form without the prior written consent of Jakob Hatteland Display AS. The products may not be copied or duplicated in any way.

